

High Capacity Multi-Purpose Waste Pump The best just got even better!

Built on more than a decade of market leading pump technology, the next generation Gulper.

3 Applications - 1 Pump

- High Capacity Grey Waste Pump - Fast drainage
- or
- Remote Mounting Bilge Pump - Easy access
- or
- Fishbox Discharge Pump - No impeller to clog / burn



Gulper[®] 320 - Applications

Application A

High Capacity Grey Waste

- **High Capacity Waste Pump - Fast Drainage**
 - Save space with faster drainage
 - Use smaller grey waste tank
 - One pump for multiple drains

HIGH CAPACITY FOR MULTIPLE DRAINS

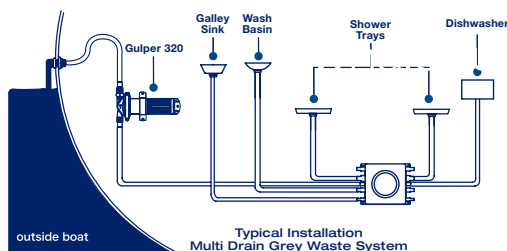

Application B

Remote Mounting Bilge

- **Easy Access Remote Mount Bilge Pump**
 - Remote mounting allows easy access
 - Meets requirement for primary bilge pump for boats up to 12m (39.4ft) length
 - Ideal where bilge space is limited

EASY ACCESS FOR INSPECTION

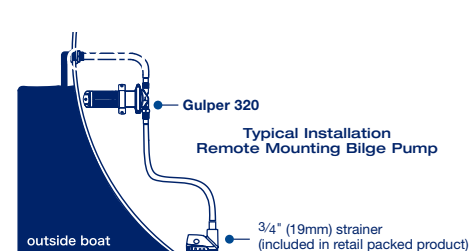

Application C

Fishbox Discharge

- **Fishbox Discharge Pump**
 - Handles fishbox waste
 - Easy to install in convenient locations

NO IMPELLER TO CLOG/ BURN

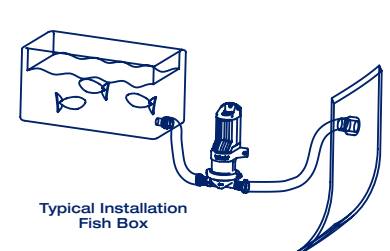

High Capacity Multi-Purpose Waste Pump

3 Applications - 1 Pump

new



**Head Rotates 360°
to best suit installation**

The best just got even better!

- Non-choke valves - no filter to block or clean
- Easy to install - including uneven surfaces
- Only 3 screws to secure
- Secure fit - new wrap around mounting feature
- Head rotates 360 degrees to suit your installation
- Self primes and runs dry

MODEL SPECIFICATIONS

Model	Gulper 320	
Product Code (retail)	BP2052	BP2054
Product Code (bulk)	BP2052B	BP2054B
Voltage	12 V d.c.	24 V d.c.
Hose Connections	3/4" (19mm) + 1" (25mm)	
Recommended Fuse Size	10 Amp	5 Amp
Minimum Wire Size	1.5 mm ² (16 AWG)	
Weight	1.6 kg (3.5 lbs)	
Materials	Pump Head: Glass-filled Nylon Valves and Diaphragm: Santoprene	
Service Kits	AK2050 (replacement head)	
Accessories	3/4" (19mm) strainer (multi-directional port) SB3422 (top/side entry - retail packed) SB3422B (side entry - bulk packed) SB3465B (top entry - bulk packed)	
Maximum Suction Lift	3m (10ft)	
Maximum Discharge Head	3m (10ft)	
Maximum Discharge Head and Suction Lift	4m (13.5ft)	

PERFORMANCE DATA

Model	BP2052 / BP2054			
Suction Lift	0m / ft	0m / ft	1m (3ft)	1m (3ft)
Discharge Head	1m (3ft)	1m (3ft)	1m (3ft)	1m (3ft)
Hose Size	3/4"	1"	3/4"	1"
Flow Rate per Minute	19 ltrs (5 US gals)	17.5 ltrs (4.6 US gals)	17.4 ltrs (4.5 US gals)	15.5 ltrs (4.1 US gals)
Current Draw	7.5 amps (12 V d.c.) 3.25 amps (24 V d.c.)	8 amps (12 V d.c.) 4 amps (24 V d.c.)	7.5 amps (12 V d.c.) 3.25 amps (24 V d.c.)	8 amps (12 V d.c.) 4 amps (24 V d.c.)

Approvals

ISO15083 Marine standard for vessels up to 12m (39.4 ft) in length
ISO8849 Ignition protected
CE marked

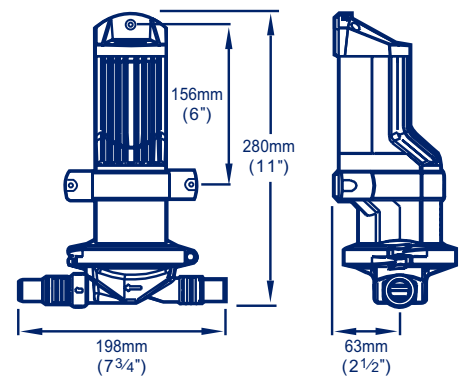

3 year warranty

Whale Water Systems

Old Belfast Road, Bangor, BT19 1LT. N.Ireland.
 tel: +44 (0)28 9127 0531 fax: +44 (0)28 9146 6421
 whalepumps.com info@whalepumps.com

Whale Water Systems Inc

PO Box 1788, 91 Manchester Valley Road,
 Manchester Center, VT 05255, USA.
 tel: +1 802 367 1091 fax: +1 802 367 1095
 whalepumps.com usasales@whalepumps.com